

# ECB SERIES

Counting Scale

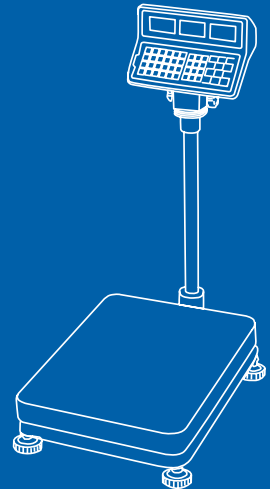

[www.globalcas.com](http://www.globalcas.com)

OWNER'S MANUAL

# CAS

# CONTENTS

<b>1. Precautions Before Using The Scale</b>	<b>5</b>
<b>2. Overall view</b>	<b>8</b>
<b>3. Installation</b>	<b>9</b>
<b>4. Explanation Of Display Symbols</b>	<b>11</b>
<b>5. Keypad Functions</b>	<b>13</b>
<b>6. Operations</b>	<b>14</b>
A.Switch on / off	14
B.Zero the scale	14
C.Sampling before counting	14
D.How to use memory cells	16
E.Subtract container's weight	18
F. Weight/Quantity accumulation	21
G.Preset counting check range	22
H.Preset weight check range	24
<b>7. User Programming Functions</b>	<b>26</b>
A.Auto. shut off time setting	26
B.Zero Tracking range	27
C.Zero display range	27
D.Stable class range	28
E.Stable class rate	28
F. Backlight type	29
G.Change unit of measure from kg to pound	30
H.Unit weight recomputing	31
I.Check alarm type	32
J.Baud rate setting	34
K.Transmit method setting	34
L.Label format setting(available when a label printer is connected.)	35
M.Cancel Tare setting	35



<b>8. Calibration(can be done in kg/lb) .....</b>	<b>36</b>
<b>9. Power supply &amp; battery operation .....</b>	<b>37</b>
<b>10. RS-232 Output .....</b>	<b>38</b>
<b>11. Error Codes.....</b>	<b>45</b>
<b>12. Technical Data .....</b>	<b>46</b>

# 1. Precautions Before Using The Scale

## **Warning**

Precautions when installing the scale. To ensure that you get the most from your scale, please follow these instruction.

**Do not disassemble the scale.**

When any damage or defect occurs, contact your CAS authorized dealer immediately for proper repair.



**Do not overload beyond the maximum weight limit.**

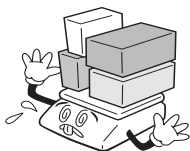

**Scale must be grounded to minimize electricity static.**

This will minimize defect or electric shock.



**Do not pull the plug by its cord when unplugging.**

Damaged cord could cause electric shock or fire.



**To prevent from fire occurring, Do not place or use the scale near flammable or corrosive gas.**

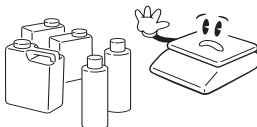

**To reduce electric shock or incorrect reading, Do not spill water on the scale or place it in humid condition.**

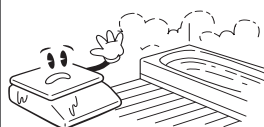

**Avoid placing the scale near heater or in direct sunlight.**

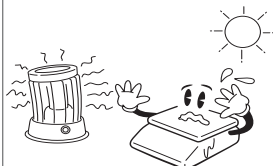

**Insert plug firmly to wall outlet to prevent electric shock.**

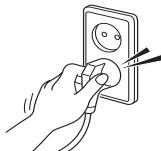

**Use proper Adapter.**

Incorrect adapter could damage the scale.

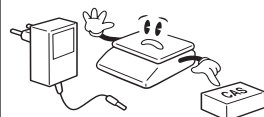

## Attention

Make sure to plug your scal into the proper power outlet. For maximum performance, plug into a power outlet 30 minutes before the usage for warm up.

For consistent and accurate reading, maintain periodical check by your CAS authorized dealer.



Avoid sudden shock to the scale.



Grab on the bottom of the scale when moving.



Keep the scale away from other electromagnetic generating devices.

This may interfere with accurate reading.



Place the scale on firm and temperature consistent environment.



By adjusting 4 comers of the scale, set the scale even using the built in scale leveling indicator.



Take the battery out when scale is not in use for long time. Leakage from the batteries is hazardous.

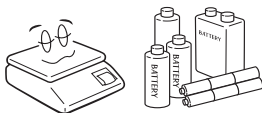

## Environment

The scale should always be used in an environment, which is free from excessive air currents, corrosives, vibration, and temperature or humidity extremes. These factors will affect displayed weight reading.

### **DO NOT** install the scale :

- Next to open windows or doors causing drafts or rapid temperature changes.
- Near air conditioning or heating vents.
- Near vibrating, rotating or reciprocating equipment.
- Near magnetic fields or equipment that generates magnetic fields.
- On an unstable work surface
- In a dusty environment
- In direct sunlight.

## Leveling the Scale

The scale is equipped with a level indicator on the back side at the middle of platform and four adjustable leveling feet. Adjust the leveling feet until the bubble appears in the center of the circle.

## Turn on Scale

Do not turn on scale with anything on the platform.

After switch at the bottom of indicator ON, The scale will start to count down from 9 to 0. It is self checking time to be ready for use the scale.

Besides, should give a warm-up for 15 ~ 30 minutes before use.

## 2. Overall view

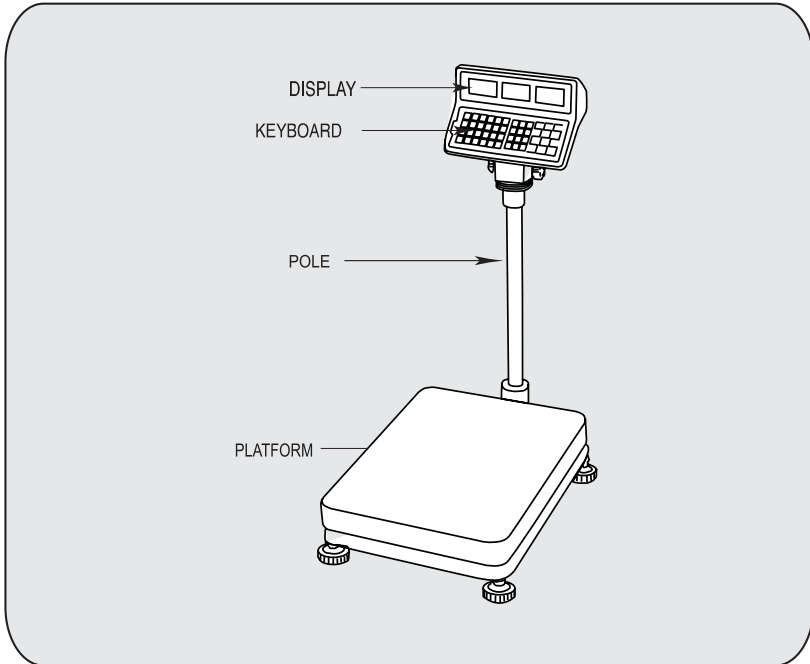

### 3. Installation

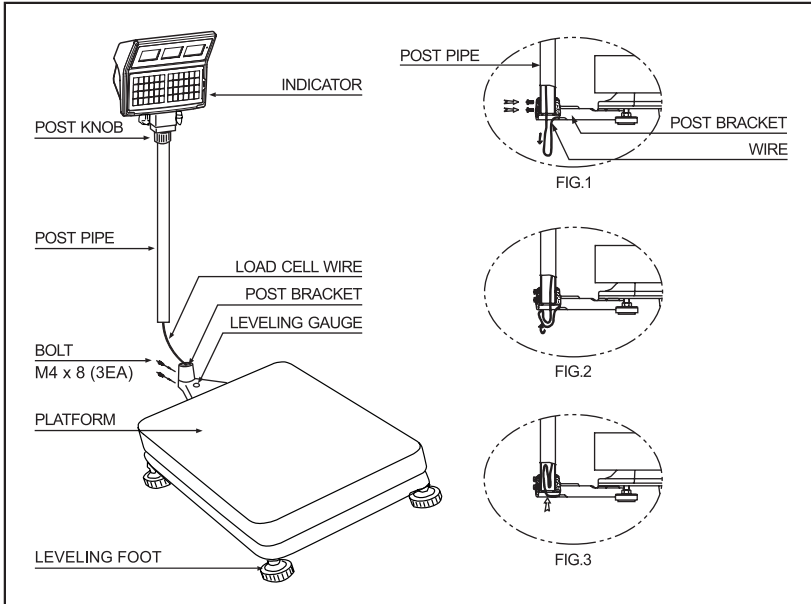

#### MODEL : ECB Series

1. Open the box with care because indicator is connected to the scale with load cell wire.
2. Turn the post knob so as to fix indicator.
3. Pull down the wire out of post pipe and insert the post pipe to the post bracket. (Refer to fig. 1)
4. Fasten the post pipe with two bolts. (Refer to fig. 1)
5. Insert the wire to the post pipe. (Refer to fig. 2, 3)
6. If the scale is not properly level, please adjust 4 leg (adjusting bolt) at the bottom of the scale so as to center the bubble of the leveling gauge.

※ Note : Place the scale on a flat and stable surface.  
Inside the indicated circle.



※ **Note:** Before using the scale, unscrew the five shipping protection screws. If not, the weighing operation works wrong.

## 1) Location of screws

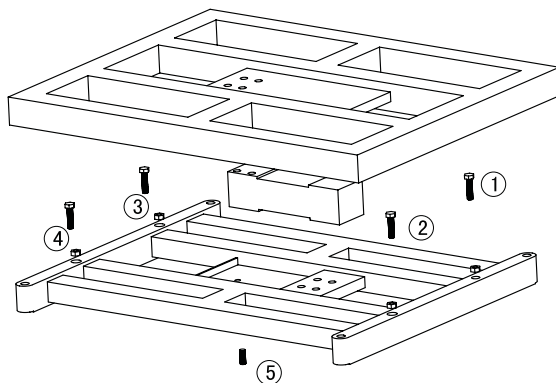

## 2) Adjusting procedure

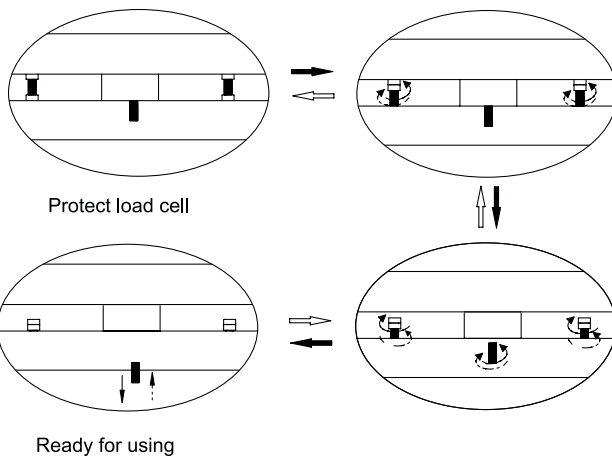

## 4. Explanation Of Display Symbols

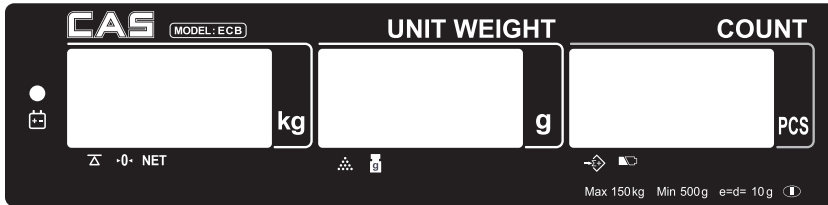

### 1) Display Windows

- Weight Display: Total 6 digits for weight accumulated or being measured on the platform.
- Unit Weight Display: Total 6 digits for unit weight or times of weight accumulated.
- Count Display: Total 6 digits for number accumulated or being counted on the platform.



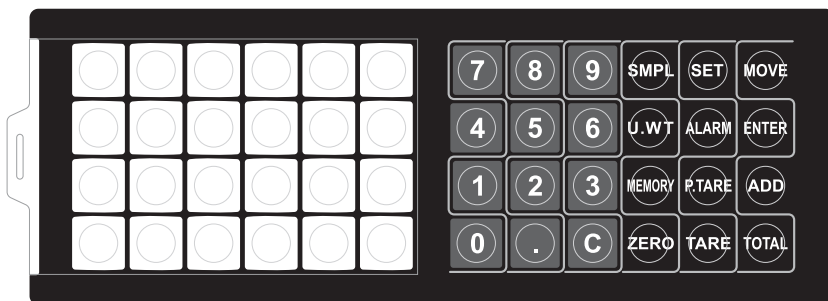

### 2) Indicated Symbols

Symbols	Specification
NET	Scale is in TARE mode.
▷0◁	Scale is in ZERO mode.
→Σ+	Scale is in ACCUMULATION mode.
△	The display reading is in STABLE condition.
•••••	<b>Lack of Sample Weight</b> If the total sample weight on the platform is less than <b>10 display divisions</b> , a triangular indicator will appear to remind the user to add more samples until the indicator disappears.
g	<b>Lack of Unit Weight</b> If the unit weight is less the 1/10 display divisions, a triangular indicator will appear to remind the user that the displayed unit weight is too small for getting accurate quantity calculations.
⏻	Low Voltage

## 5. Keypad Functions



Keys	내용
0 ~ 9	Numeric keys
.	Decimal point key
C	Use this key to clear out the displayed numeric readings.
ZERO	If there is a minor weight displayed without anything on the platform, press the zero key to clear the display.
TARE	Use this key to subtract the container's weight, indicates that the current weight reading is net weight.
SMPL	Use this key to input sample size.
U.WT	Use this key to input the known unit weight of item to be counted.
ALARM	Use this key to input the HIGH & LOW weight/quantity limit for check function.
ADD	Use this key to accumulate weight/quantity measured.
TOTAL	Use this key to recall total weight, count & accumulation on times.
P.TARE	Use this key to preset TARE weight.

	Use this key to enter into User Programming Functions.
	Use this key to confirm the parameter setting
	Use this key to move the parameter value in Set Mode.
	Use this key to memory a value to a location.
	Use these 24 blank keys to store values in memory.

## 6. Operations

### A. Switch ON/OFF

Push the on & off switch at the bottom of indicator to turn on or off the scale.

### B. Zero the scale

Press ZERO key to return the display to zero in case there is any zero drifting while unloaded.

### C. Sampling before counting

#### 1) Unknown unit weight

- Place a few pieces of item to be counted on the platform.

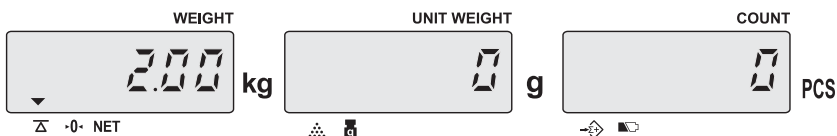

- Input the quantity of item on the platform.. (ex. 50pcs)

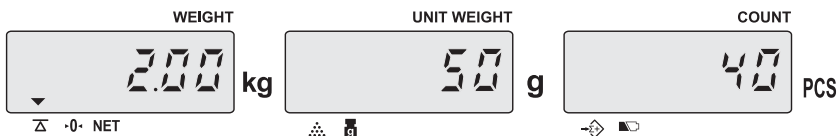

- Press SMPL key

**Note :** The system default is “Unit Weight”. If the “SMPL” key is clicked when the value (ex : 40) in COUNT window is blinking, then the numerical value input will be as “Quantity”.

If the “SMPL” key is not clicked when the value (ex : 40) in COUNT window is blinking, then the numerical value input will be as “Unit Weight”.

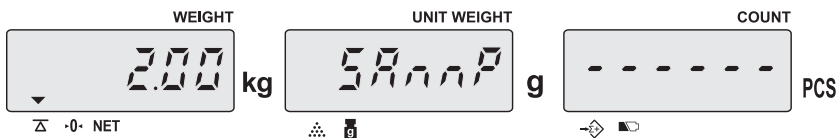

- The sampling operation is completed while stable display appears as below :

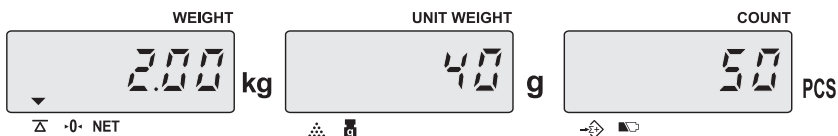

- ※ The larger sample size, the more accurate unit weight
- ※ Press **SMPL** key to recomputing unit weight during in counting process if the setting of "Unit Weight Recomputing" set to "on"

## 2) Known unit weight

- Input the known unit weight. (ex. 40g)

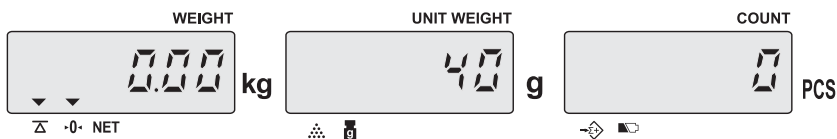

- Press **U.Wt** key to complete sampling operation & enter into counting mode.

**Note :** The system default is "Unit Weight". If the "U.WT" key is clicked when the value (ex : 0) in COUNT window is blinking, then the numerical value input will be as "Unit Weight".

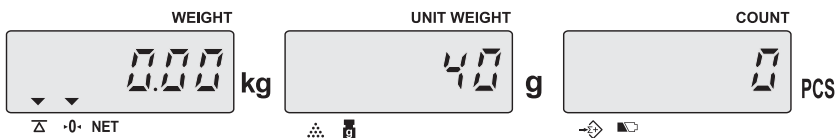

## D. How to use memory cells

### 1) How to store into direct/indirect memory cells

- Give a long press of **MEMORY** key. Then the display as below will be shown up.  
Input the unit weight values by using numeric key(ex. 35g). After input U/W, press **ENTER** key to to Confirm it and move on the next step.

**Note :** Press the **MOVE** key to change the value when a wrong value is entered.

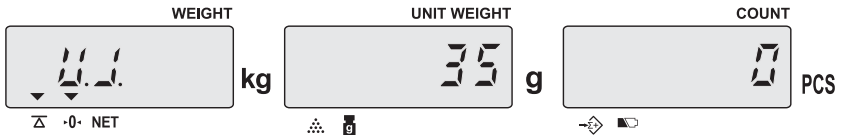

- The second step is for storing Tare value. So, Input the tare value (ex. 10kg) and press the **ENTER** key to confirm it and move on the next step.

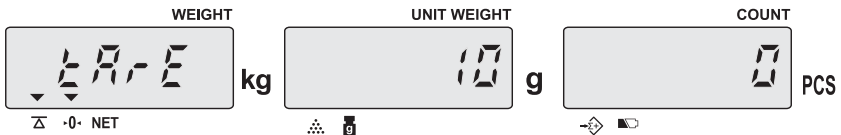

- The third step is for storing item number. So, Input the item number (ex. 800125) and press the **ENTER** key to confirm it and move on the next step.

**Note :** You can enter up to 6 digits

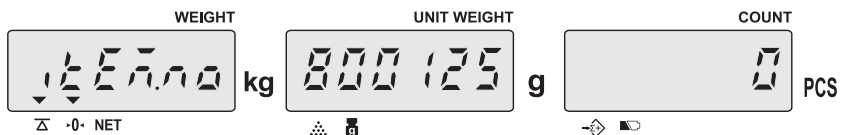

- The fourth step is for storing address cell. There are two memory spaces :  
Direct memory / In-Direct memory:

**[Into direct memory]**

Press one of **Direct memory** keys (Total 24 keys) which you want to use stored values for recalling.  
Then, the scale will be back to the normal counting mode directly.

**[Into indirect memory]**

Input an address number by using Numeric key(1~100) and Press **ENTER** key to confirm it.  
Then, the scale will be back to the normal counting mode directly.

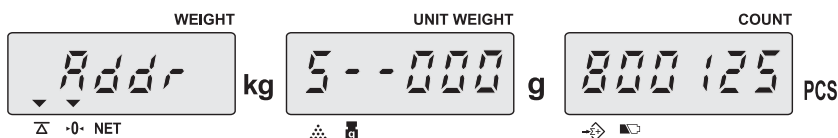

- ※ 1) An error message “E4” appears if the address code is out of “1 ~ 100”.  
Then press **MOVE** key to return to last step. Press **CANCEL** key to exit the storing mode.
- 2) When the address number has been used, the display will be shown as below.  
At this time, if you want to still use the address number, press **ENTER** key to confirm it



If you want to change the address number, press **MOVE** key to go back to the fourth step again.

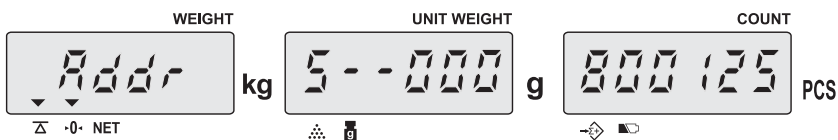



## 2) How to recall stored memory

### [From direct memory]

Just press the **direct memory** key one time which you already stored in it.

### [From indirect memory]

Press the address number by using numeric keys which you want to recall and then press **MEMORY** key Twice rapidly.

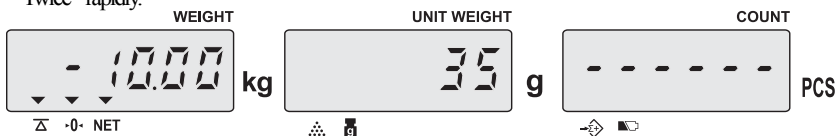

- ※ 1) Place parts on the platform, you will know the number of parts.
- 2) Press the C key to exit from recalling memory mode.
- 3) Press the U.WT key during recalling memory mode to check address & item number.

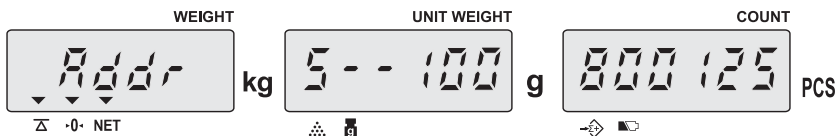

## E. Subtract container's weight

### 1) Weight unknown

- Place a container on the platform.

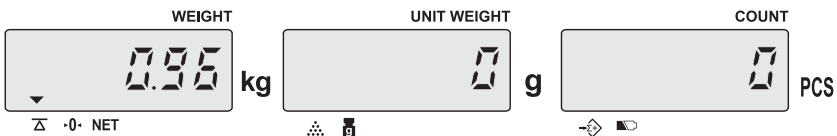

- Press **TARE** key

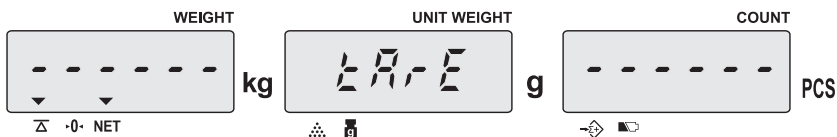

- After operate Tare function well, indicators of stable ( $\Sigma$ ) & Net weight (NET) will appear as below.

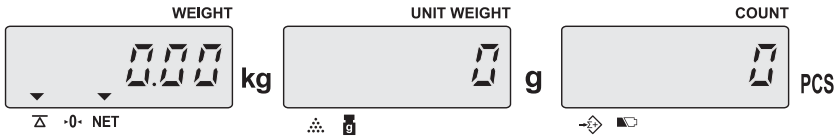

## 2) Container's weight known

- ☞ With no weight on the platform  
Nothing on the platform

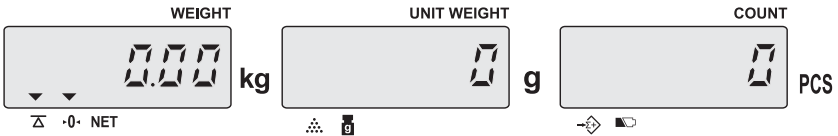

- Press **P.TARE** key

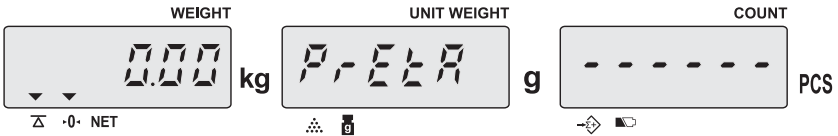

- Input container's weight value by using numeric keys(ex.0.96kg)

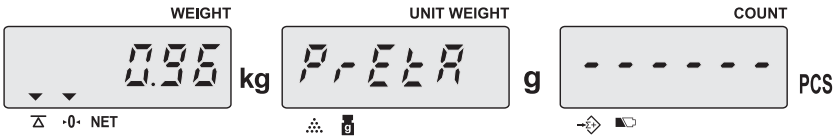

- Press **P.TARE** key again.

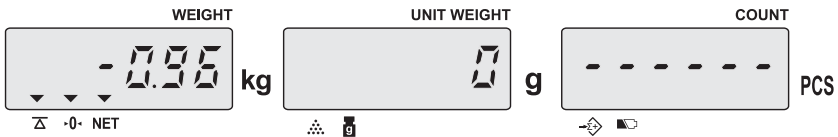

☞ With some weight on the platform

Scale is loaded

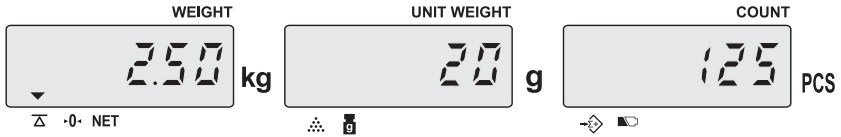

- Press **P.TARE** key

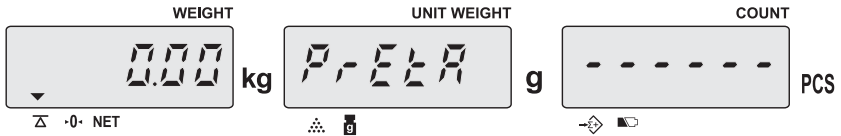

- Input container's weight value by using numeric keys (ex. 0.5kg)

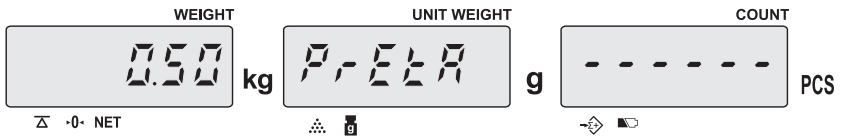

- Press **P.TARE** key again.

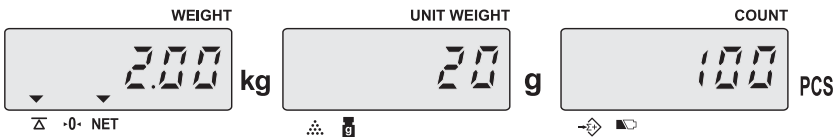

Remove all weights from the platform. If so the weight display will show a negative (-) container's weight. At this moment, Pressing **TARE** key will bring the weight display to zero. Then TARE indicator(NET) will be disappeared.

## F. Weight/Quantity accumulation

- Place item to be weighed / counted on the platform.

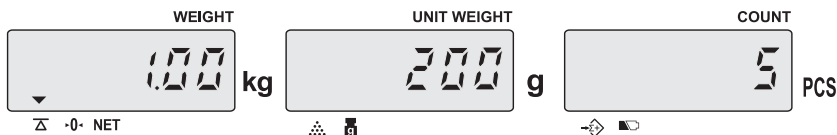

- Press **ADD** key. Display images will be shown as below in sequence.

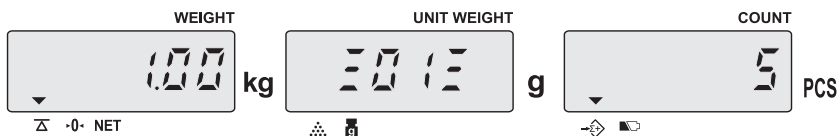
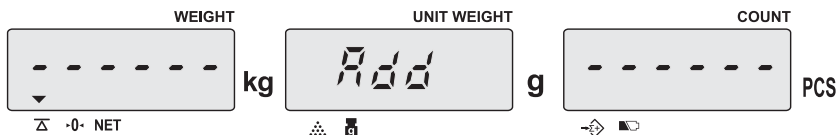

- Press **TOTAL** key or wait approx. 2 seconds, the scale will return to counting mode.

※The weight window should be zeroed before the next accumulation.

- Following to the process above, you can add up whatever you want continuously.  
After then press **TOTAL** key. Then the total weight will be shown on WEIGHT window, the total count will be shown on COUNT window and the number of accumulation will be shown on UNIT WEIGHT window.

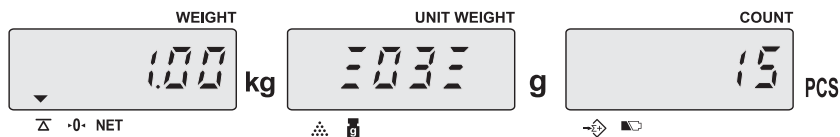

- Press **TOTAL** key to enter into accumulation status mode. At this moment, total accumulated weight is shown on WEIGHT window, total accumulated times is shown on UNIT WEIGHT window and TOTAL PIECES is shown on count window.  
Press **TOTAL** key again to go back to counting mode.

### ※ Clear accumulation

Press **TOTAL** key to enter into accumulation status mode and press **CLEAR** key to clear all accumulated data.

- 1) The display window will show "—OL—" when accumulated value exceed the display range.
- 2) The maximum accumulation time is 99.
- 3) The weight window should be zeroed before the next accumulation.

## G. Preset counting check range

User can set a Hi – Lo range for checking the quantity of counting result, when the number of objects on the platform meet the condition of the range, the alarm will sound beeps repeatedly.

### 1) Procedures

- Doesn't matter what something is on the platform. Press **ALARM** key. Then the display image is shown as below.

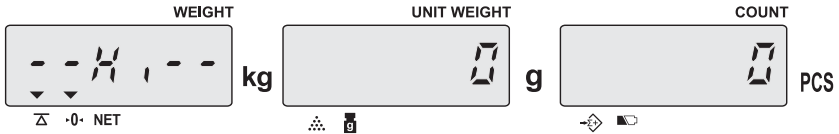

- Input desired high limit value by using numeric keys. (ex. 200pcs)  
(It is possible to erase wrong value as using **CLEAR** key.)

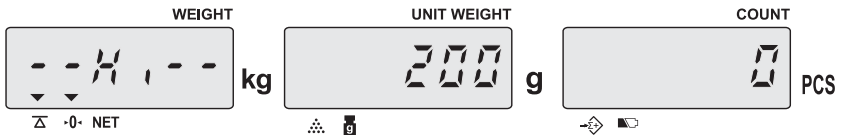

- Press **ALARM** key again to confirm HI value and move on next step to input LO value.  
Input desired LO limit by using numeric keys(ex. 5pcs)  
(Low limit value is effective only after high limit is preset )

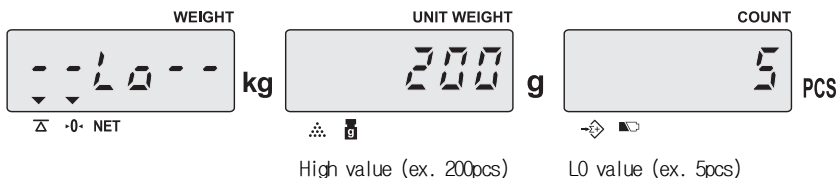

- Press **SMPL** key to complete this procedure and return to normal counting mode.

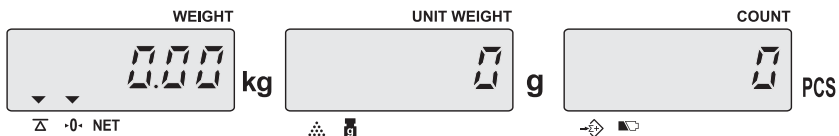

※ **Note** : An error message “E5” appears in weight window when the LO value is set higher than HI value. A few seconds later, it will back to limit setting mode again.

## H. Preset weight check range

Users can set a Hi – Lo range for checking weight value, when the weight value of objects on the platform meet the condition of the range, the alarm will sound beeps repeatedly.

### 1) Procedures

- Doesn't matter what something is on the platform.  
Press **ALARM** key. Then the display image is shown as below.

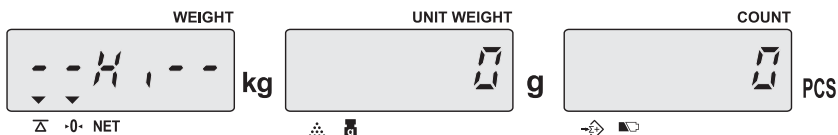

- Input desired high limit value by using numeric keys.(ex. 30kg)  
(It is possible to erase wrong value as using **CLEAR** key )

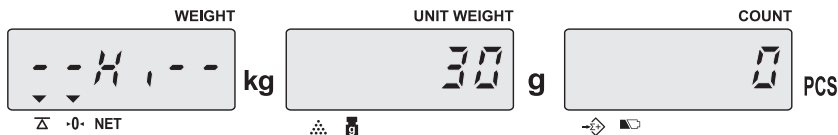

- Press **ALARM** key again to confirm HI value and move on next step to input LO value.  
Input desired LO limit by using numeric keys (ex. 2kg)  
(Low limit value is effective only after high limit is preset)

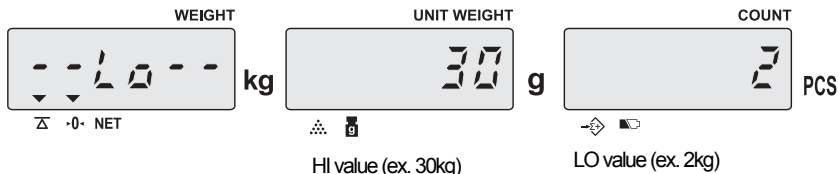

- Press U.Wt key to complete this procedure and return to normal weighing mode.

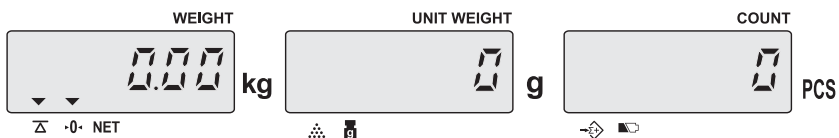

- ※ **Note :** 1) An error message "E5" appears in weight window when the LO value is set higher than HI value.
- 2) When both HI and LO values are needed, they must be kept same decimal digits. (Ex. HI=10kg, LO=9.8kg, then the values must be set as "HI=10.0kg, LO=9.8kg".)

※ **Clear high / low value preset**

Input "0" or **Clear** key to delete prior HI/LO values, when you are in limit setting mode.



## 7. User Programming Functions

User programming mode is for Users. There are thirteen setting menus.

To enter User programming mode, press **SET** key. Then the PASS WORD inputting is needed.

Input “101010” and then press **ENTER** key to get into real user programming mode.

Once the scale is in User programming mode, the first menu is **Auto shut off time setting**.

- \* The display shows “error” to prompt the mistake when the pass word is wrong.
- \* If wrong pass word is inputted two times, then the scale will return to weighing mode automatically.

### A. Auto. Shut off time setting

- As shown below, the setting value is on WEIGHT window and the title of menu is on U/W window

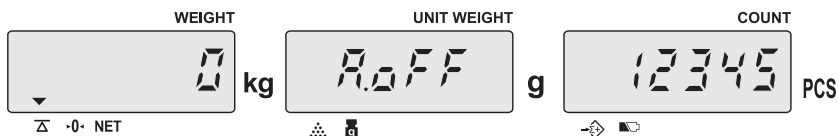

- There are 4 options, and Pressing **MOVE** key is possible to rotate among the options.

Options	Description
0 (Default setting)	No use this function
2	The scale will be turned off automatically after 2 min, if there is no any interruption.
5	The scale will be turned off automatically after 5 min, if there is no any interruption.
8	The scale will be turned off automatically after 8 min, if there is no any interruption.

- If you want to exit, press **C** key to confirm and go back to normal weighing mode.  
However, if you want to keep going to set other menus, press **ENTER** key to confirm and move on next.

※ Please turn off the scale after setting.

## B. Zero Tracking Range

- Keep pressing **ENTER** key in USER PROGRAMMING MODE until the display appears as below.

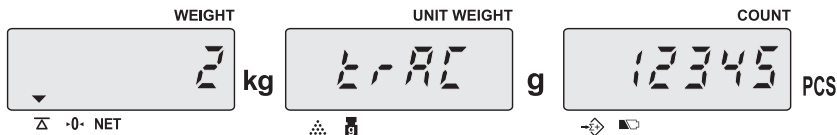

- There are 5 options, and Pressing **MOVE** key is possible to rotate among the options.  
(**Default setting:** 2)  
(0=off, 1=0.5d, 2=1d, 3=2d, 4=3d)
  - If you want to exit, press **C** key to confirm and go back to normal weighing mode.  
However, if you want to keep going to set other menus, press **ENTER** key to confirm and move on next.
- ※ Please turn off the scale after setting.

## C. Zero display range

- Keep pressing **ENTER** key in USER PROGRAMMING MODE until the display appears as below.

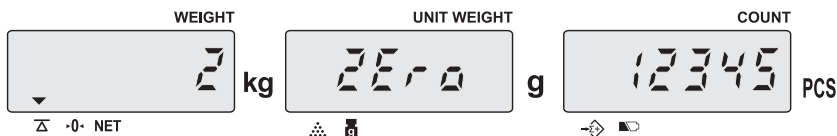

- There are 5 options, and Pressing **MOVE** key is possible to rotate among the options.  
(**Default setting:** 2)  
(0=off, 1=0.5d, 2=1d, 3=2d, 4=3d)
  - If you want to exit, press **C** key to confirm and go back to normal weighing mode.  
However, if you want to keep going to set other menus, press **ENTER** key to confirm and move on next.
- ※ Please turn off the scale after setting.

## D. Stable class range

- Keep pressing **ENTER** key in USER PROGRAMMING MODE until the display appears as below.



- There are 6 options, and Pressing **MOVE** key is possible to rotate among the options.  
(Default setting: 1)  
(0=off, 1=0.05d, 2=0.151d, 3=0.25d, 4=0.35d, 5=0.45d)
  - If you want to exit, press **C** key to confirm and go back to normal weighing mode.  
However, if you want to keep going to set other menus, press **ENTER** key to confirm and move on next.
- ※ Please turn off the scale after setting.

## E. Stable class rate

- Keep pressing **ENTER** key in USER PROGRAMMING MODE until the display appears as below.

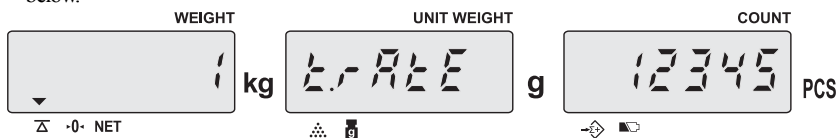

- There are 5 options, and Pressing **MOVE** key is possible to rotate among the options.  
(Default setting: 1)  
Level : 1, 2, 3, 4, 5  
The larger number is more stable.
  - If you want to exit, press **C** key to confirm and go back to normal weighing mode.  
However, if you want to keep going to set other menus, press **ENTER** key to confirm and move on next.
- ※ Please turn off the scale after setting.

## F. Backlight type

- Keep pressing **ENTER** key in USER PROGRAMMING MODE until the display appears as below.

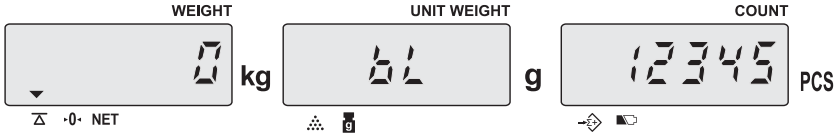

- There are 2 options, and Pressing **MOVE** key is possible to rotate among the options.  
(Default setting: 0)

- **0 – Auto. Backlight**

Backlight will be going on automatically whenever the scale is loaded by objects weigh greater than **9 display resolution** or any of keys is pressed. And it will be going off also automatically approx. 5 seconds after the scale returns to zero.

- **1 – Manual backlight**

Press  (decimal point) key to switch on and off backlight.

- If you want to exit, press **C** key to confirm and go back to normal weighing mode. However, if you want to keep going to set other menus, press **ENTER** key to confirm and move on next.

※ Please turn off the scale after setting.

## G. Change unit of measure from kg to Pound

- Keep pressing **ENTER** key in USER PROGRAMMING MODE until the display appears as below.

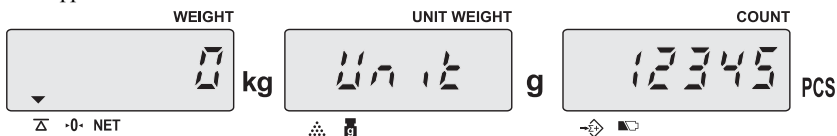

- There are 2 options, and Pressing **MOVE** key is possible to rotate among the options.  
(Default setting: 0)  
0—kg, 1—lb
  - If you want to exit, press **Clear** key to confirm and go back to normal weighing mode.  
However, if you want to keep going to set other menus, press **ENTER** key to confirm and move on next.
- ※ Please turn off the scale after setting.

## H. Unit weight recomputing

- Keep pressing **ENTER** key in USER PROGRAMMING MODE until the display appears as below.

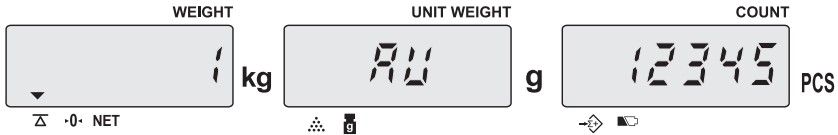

- There are 2 options, and Pressing **MOVE** key is possible to rotate among the options.  
**(Default setting: 1)**
  - 0—Disable recomputing function
  - 1—Enable recomputing function
- If you want to exit, press **C** key to confirm and go back to normal weighing mode.  
However, if you want to keep going to set other menus, press **ENTER** key to confirm and move on next.
- ※ The unit weight will be averaged again if you add the remaining quantity, gradually, by several lots. This will help eliminate errors caused by the **possible weight variation among each object** and lead to more accurate results.  
When adding objects to the platform (**The weight value should not be less than 10 display divisions.**), be sure that the quantity is LESS THAN those already on the platform. The alarm will sound a beep when the unit weight is averaged again.
- ※ Recomputing function is effective only after sampling operation is done.
- ※ Please turn off the scale after setting.

## I. Check alarm type

- Keep pressing **ENTER** key in USER PROGRAMMING MODE until the display appears as below.

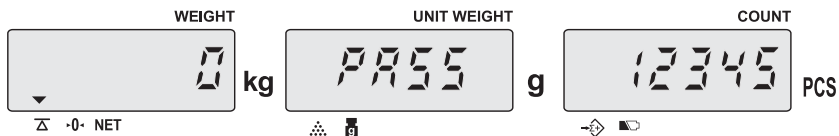

- There are 2 options, and Pressing **MOVE** key is possible to rotate among the options.  
(Default setting: 0)  
0 – Inside type  
1 – Outside type
- If you want to exit, press **C** key to confirm and go back to normal weighing mode.  
However, if you want to keep going to set other menus, press **ENTER** key to confirm and move on next.

## 1. Inside type

The alarm sounds beeps only when either total weight or total count is inside the set range.

Ex) checking the count / weight

(If the count / weight is in between LO and HI values, the value on count display window will flicker)

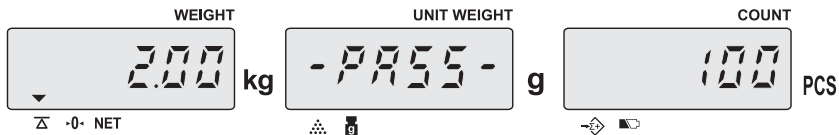

## 2. Outside type

The alarm sounds beeps only when either total weight or total count is outside the set range.

Ex) checking the count/weight when over HI value

(If the count/weight is over HI value, the value on count display window will flicker)

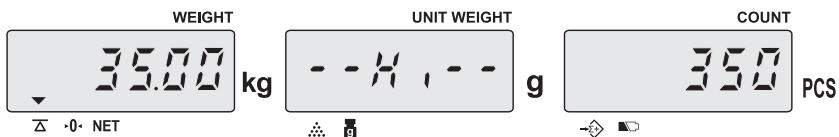

Ex) checking the count/weight when under LO value

(If the count/weight is under LO value, the value on count display window will flicker)

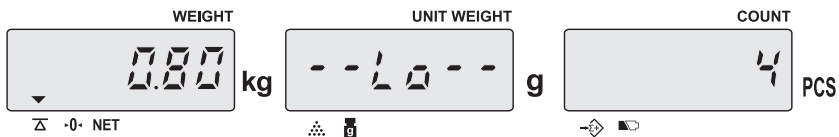

※ Please turn off the scale after setting.



## J. Baud Rate setting

- Keep pressing **ENTER** key in USER PROGRAMMING MODE until the display appears as below.



- There are 3 options, and Pressing **MOVE** key is possible to rotate among the options.  
(Default setting: 2)  
0–2400  
1–4800  
2–9600
  - If you want to exit, press **C** key to confirm and go back to normal weighing mode.  
However, if you want to keep going to set other menus, press **ENTER** key to confirm and move on next.
- ※ Please turn off the scale after setting.

## K. Transmit method setting

- Keep pressing **ENTER** key in USER PROGRAMMING MODE until the display appears as below.



- There are 4 options, and Pressing **MOVE** key is possible to rotate among the options.

Options	Description
1	transmit by pressing a key (ex. Ticket printer DEP-50, PC)
2	series transmit (ex. Ticket printer DEP-50, PC)
3(Default setting)	transmit by pressing a key (for a label printer: DLP-50)
4	auto-transmit (for a label printer : DLP-50)

- If you want to exit, press **C** key to confirm and go back to normal weighing mode.  
However, if you want to keep going to set other menus, press **ENTER** key to confirm and move on next.
- ※ Please turn off the scale after setting.

## L. Label format setting (available when a label printer is connected.)

- Keep pressing **ENTER** key in USER PROGRAMMING MODE until the display appears as below.

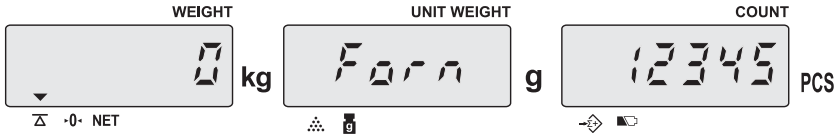

- There are 10 options, and Pressing **MOVE** key is possible to rotate among the options.  
(Default setting: 0)  
Form : 0~9
  - If you want to exit, press **C** key to confirm and go back to normal weighing mode.  
However, if you want to keep going to set other menus, press **ENTER** key to confirm and move on next.
- ※ Please turn off the scale after setting.

## M. Cancel Tare setting

- Keep pressing **ENTER** key in USER PROGRAMMING MODE until the display appears as below.

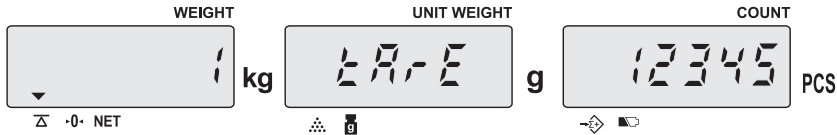

- There are 10 options, and Pressing **MOVE** key is possible to rotate among the options.  
(Default setting: 1)  
“1” – The tare can be canceled continuously.  
“2” – The tare must be canceled for one time only.  
Note : When user is trying to cancel tare value, If the value is not the same as total tare value, the buzzer will tweet for three times to indicate the error.  
Then, Remove all the weight from the platform and then press TARE key or turn off and on the scale to solve the error.
  - If you want to exit, press **C** key to confirm and go back to normal weighing mode.  
However, if you want to keep going to set other menus, press **ENTER** key to confirm and move on next.
- ※ Please turn off the scale after setting.

## 8. Calibration (can be done in kg/lb)

- After turn on, Self-checking will be started. During Self-checking, Input “000419” by using numeric keys. Then the scale will be got into simple calibration mode and the display will be shown as below.

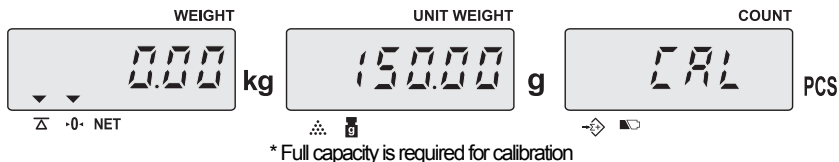

- Normally, the full capacity is displayed on U/W window because full capacity is required for calibration. However, weight capacity for calibration is possible to set by yourself as inputting numeric keys.
- After made a decision what capacity will be used for calibration, put the weight on the platform as same as what exactly shown on the U/W window. Then the scale is calibrated automatically and the scale is back to normal weighing mode a few seconds later.
- ※ Press CLEAR key to escape form calibration mode at any time.
- ※ **This calibration instruction is NOT for US market.**

## 9. Power supply & battery operation

### POWER SUPPLY

- (1) AC Adaptor
- (2) DC 12V/800mA or 12V/1000 mA

### BATTERY OPERATION

The scale can be operated from the battery if desired. When the backlight is off, The battery life is approximately 100hours .

When the battery need to be charged, a symbol “  ” on the COUNT display will turn on. The scale can keep operating for about 10 hours after the symbol appears. The scale will automatically switch off to protect the battery. Before switching off automatically, a prompt words “Lobat off” will be shown three times to indicate the scale switch off due to battery empty.

The battery should be charged for 12 hours for full capacity.

There is an LED to indicate the status of battery charging on the display. If the LED is **Green** the battery has been charged. If it is **Red** the battery is nearly discharged and **Yellow** indicates the battery is increasing the charge level.

If a current battery fails to full-charge or battery life is too short, Please contact to your distributor.

**Note:** The battery should be recharged every 3 months if the scale is not used for long time.

## 10. RS-232 Output

The scale can be ordered with as optional RS-232 output.

1. Mode EIA-RS 232C's UART signal
2. Format:

Baud rate: 9600 BPS

Data bits: 8 BITS

Stop bit: 1 BIT

Code ASCII

Connector: 9 Pin Socket

Pin2 Input

Pin3 Output

Pin5 Signal Ground

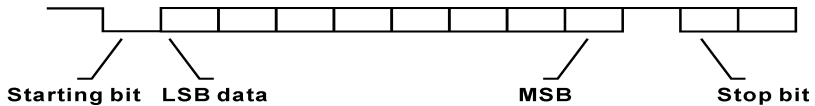

Data digit specification	1 2 3 4 5				6	7 8 9 10 11 12 13							14 15 16		17 18			
	1 <sup>st</sup> row: Net weight-Data	title	space	data			unit	CR										
2 <sup>nd</sup> row: Unit weight-data	title	space	data			unit	CR											
3 <sup>rd</sup> row: Quantity-data	title	space	data			CR(14 15)												
4 <sup>th</sup> row: Tare weight-data	title	space	data			weight	CR											
4 <sup>th</sup> row data.	OA																	

3. Data Format of Series transmit:

**When it is in unstable mode:**

net: 15.000 kg

UWV: 1000 g

pcs: 10

Tare: 5.000 kg

**When the scale is in stable mode:**

NET: 15.000 kg

U/W: 1000 g

PCS: 10

Tare: 5.000 kg

net=Unstable Net Weight

NET= Stable Net Weight

pcs=Unstable Quantity

PCS= Stable Quantity

UW=Unit Weight

Tare=Tare value

4. Transmit Format, when it is in Accumulation mode and transmit by pressing “**ADD**” key and “**TOTAL**” key.

**Press the ADD key**

PLU100

No. 800125

Record#01

NET: 15.000 kg

U/W: 100.00 g

PCS: 100

Tare: 5.000 kg

**Press the ADD key again**

PLU100

No. 800125

Record#02

NET: 10.000 kg

U/W: 100.00 g

PCS: 80

Tare: 2.000 kg

**Press the TOTAL key**

TOTAL

PLU100

No. 800125

NET: 25.000 kg

pcs: 180

**Note:** When it is in normal counting model (without accumulation operation), press the “TOTAL” key to print the data, the transmit format is as below:

**When it is in stable mode:**

TOTAL

NET: 15.000 kg

UW: 100.00 g

PCS: 100

Tare: 5.000 kg

**When it is in unstable mode:**

TOTAL

net: 15.000 kg

UW: 100.00 g

pcs: 100

Tare: 5.000 kg

NET=Stable Net Weight

PCS=Stable Quantity

UW=Unit Weight

net=Unstable Net Weight

pcs=Unstable Quantity

Tare= Tare value

5. Label printer format.

●used “dot”, in accumulation mode:

- Press **ADD** key

(Weight: 6.48kg/Unit weight: 20.25g/Quantity: 320pcs/Tare: 0.035kg)

CAS Counting Scale: ECB	
	<b>6.48 kg</b> 20.25g/PC <b>320 PCS</b> IN: 123456 AN: 100 16-DEC-2008 16:37:11
1 234560 003204	
TARE: 0.035 kg	

- Press **ADD** key again

(Weight: 4.55kg/Unit weight: 20.25g/Quantity: 220pcs/Tare: 0.035kg)

CAS Counting Scale: ECB	
	<b>4.455 kg</b> 20.25g/PC <b>220 PCS</b> IN: 123456 AN: 100 16-DEC-2008 17:43:56
220	
TARE: 0.035 kg	

- Press **TOTAL** key

(Weight: 10.935kg/Unit weight: 20.25g/Quantity: 540pcs/Tare: 0.035kg)

CAS Counting Scale: ECB	
	<b>10.935 kg</b> 20.25g/PC <b>540 PCS</b> IN: 123456 AN: 100 16-DEC-2008 17:48:30
540	
TARE: 0.035 kg	

●used “comma”:

CAS Counting Scale: ECB	
	<b>6,48 kg</b> 20.25g/PC <b>320 PCS</b> IN: 123456 AD: 100 16-DEC-2008 15:30:51
1234567	
TARE:0,035 kg	

●with “EAN13 barcode”:

CAS Counting Scale: ECB	
	<b>6.48 kg</b> 20.25g/pc <b>320 PCS</b> IN: 123456 AN: 100 16-DEC-2008 16:37:11
1 234560 003204	
TARE: 0.035 kg	



## 6. Pin Connection

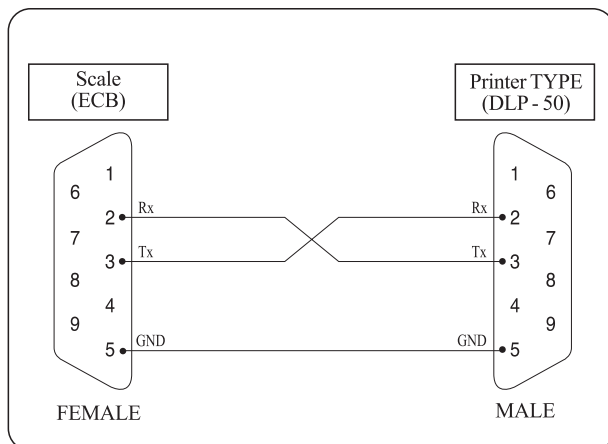

Connect ECB and Printer using same cable. [Female(ECB) – Male(DLP-50)]

## 7. Key – Command ( by Transmit method setting is set “1”)

Command(1 byte)		Weighing Mode
Char.	Hex	
1	0x31	Same as 1 key
2	0x32	Same as 2 key
3	0x33	Same as 3 key
4	0x34	Same as 4 key
5	0x35	Same as 5 key
6	0x36	Same as 6 key
7	0x37	Same as 7 key
8	0x38	Same as 8 key
9	0x39	Same as 9 key
0	0x30	Same as 0 key
.	0x2E	Same as “.” key
C(c)	0x43	Same as <b>C(Clear)</b> key
	0x63	

S(s)	0x53	Same as <b>SMPL</b> key
	0x73	
O(o)	0x4F	Same as <b>SET</b> key
	0x6F	
M(m)	0x4D	Same as <b>MOVE</b> key
	0x6D	
U(u)	0x55	Same as <b>U.WT</b> key
	0x75	
A(a)	0x41	Same as <b>ALARM</b> key
	0x61	
E(e)0	0x45	Same as <b>ENTER</b> key
	0x65	
R(r)	0x52	Same as <b>MEMORY</b> key
	0x72	
P(p)	0x50	Same as <b>P.TARE</b> key
	0x70	
N(n)	0x4E	Same as <b>ADD</b> key
	0x6E	
Z(z)	0x5A	Same as <b>ZERO</b> key
	0x7A	
T(t)	0x54	Same as <b>TARE</b> key
	0x74	
D(d)	0x44	Same as <b>TOTAL</b> key
	0x64	
L(l)	0x4C	Same as Long press <b>MEMORY</b> key
	0x 6C	

8. Variables(The prompt character) used in scale also in label printer

Variable Name	Specifications	Size
SER	Accumulated times (Weight)	2 byte
NWA	Net weight (with dot ".")	7 byte
NWB	Net weight(no dot)	6 byte
NWC	Net weight(with comma ",")	7 byte
TWA	Tare weight (with dot ".")	7 byte
TWB	Tare weight (no dot)	6 byte
TWC	Tare weight (with comma ",")	7 byte
GWA	Gross weight (with dot ".")	7 byte
GWB	Gross weight (no dot)	6 byte
GWC	Gross weight (with comma ",")	7 byte
TNA	Total net weight (with dot ".")	7 byte
TNB	Total net weight(no dot)	6 byte
TNC	Total net weight (with comma ",")	7 byte
UWA	Unit weight (with dot ".")	7 byte
UWB	Unit weight (no dot)	6 byte
UWC	Unit weight (with comma ",")	7 byte
QUA	Quantity (with dot ".")	7 byte
QUB	Quantity (no dot)	6 byte
QUC	Quantity (with comma ",")	7 byte
TQA	Total Quantity (with dot ".")	7 byte
TQB	Total Quantity (no dot)	6 byte
TQC	Total Quantity (with comma ",")	7 byte
UNT	Weighing Unit	2 byte
AN	Address number	3 byte
IN	Item number	6 byte

※ Note: 1) Capital Letters are allowed for the Variable Name only.

2)A value "0" will be given the value exceeds the display range.

# 11. Error Codes

While using the scale, it might be happened to show ERROR message unexpectedly.  
There is an ERROR message description as below.

<b>Error Code</b>	<b>Possible Causes</b>	<b>Handling</b>
<b>E1</b>	Calibration data lost	Re-calibrate the scale
<b>E2</b>	The stored data lost	Re-calibrate the scale
<b>E3</b>	Turn on the scale with something on the platform.	Take away all goods from the platform and switch on again.
<b>E4</b>	Address cell is out of "1 ~ 100".	Correct the operation.
<b>E5</b>	In alarm setting, the LO value is set higher than HI value.	Correct the operation.
<b>OL</b>	Overload or value exceeds the display range.	Correct the operation.

If the error message still is shown even after following to description, please do calibrate again.  
After then, if the problem still happens, contact to your dealer for further support.

## 12. Technical Data

Kg Version	Capacity	<b>30kg</b>	<b>75kg</b>	<b>150kg</b>	<b>250kg</b>
	Readability (e=d)	0.002kg	0.005kg	0.01kg	0.02kg
	Resolution	1/15,000	1/15,000	1/15,000	1/12,500
lb Version	Capacity	<b>60lb</b>	<b>150lb</b>	<b>300lb</b>	<b>500lb</b>
	Readability (e=d)	0.005lb	0.01lb	0.02lb	0.05lb
	Resolution	1/12,000	1/15,000	1/15,000	1/10,000
Internal Resolution	1/600,000				
Min Recommended Lack of Sample Weight	0.02kg	0.05kg	0.1kg	0.2kg	
	0.05lb	0.1lb	0.2lb	0.5lb	
Min Recommended Lack of Unit Weight	0.2g	0.5g	1g	2g	
	0.0005lb	0.001lb	0.002lb	0.005lb	
Display Type	LCD				
Weight Units	kg or lb				
Zero Range	±2%				
Tare Tange	Full Capacity by Subtraction				
Stabilization Time	≤2 seconds				
Operation Temperature	0°C ~ 40°C /32°F ~ 104 °F				
Humidity Range	≤90% relative humidity, non-condensing				
Power	AC Adaptor DC 12V/1A or 12V/800mA Internal rechargeable sealed acid battery				
Battery Life	100 hours continuous use with 12 hour recharge time(Backlight OFF)				
Calibration	Automatic external with kg/lb mass, factory calibration recovery				
Safe Overload Capacity	120% of capacity				
Platform size(mm)	400(W) x 500(D)				
Dimension(mm)	500(W) x 720(D) x 760(H)				



# ECB SERIES

Counting Scale



CAS BLDG., # 440-1, SUNGNAE-DONG,  
GANGDONG-GU, SEOUL, KOREA

TEL\_ 82 2 2225 3500

FAX\_ 82 2 475 4668

[www.globalcas.com](http://www.globalcas.com)